

Static aspirator and cutter for technical filament yarns and staple fiber tow. They are designed for technical filament yarns, tow and carpet yarns of different fiber raw material for speedup to 8000 mtr /min and a denier of up to 35000 dtex.

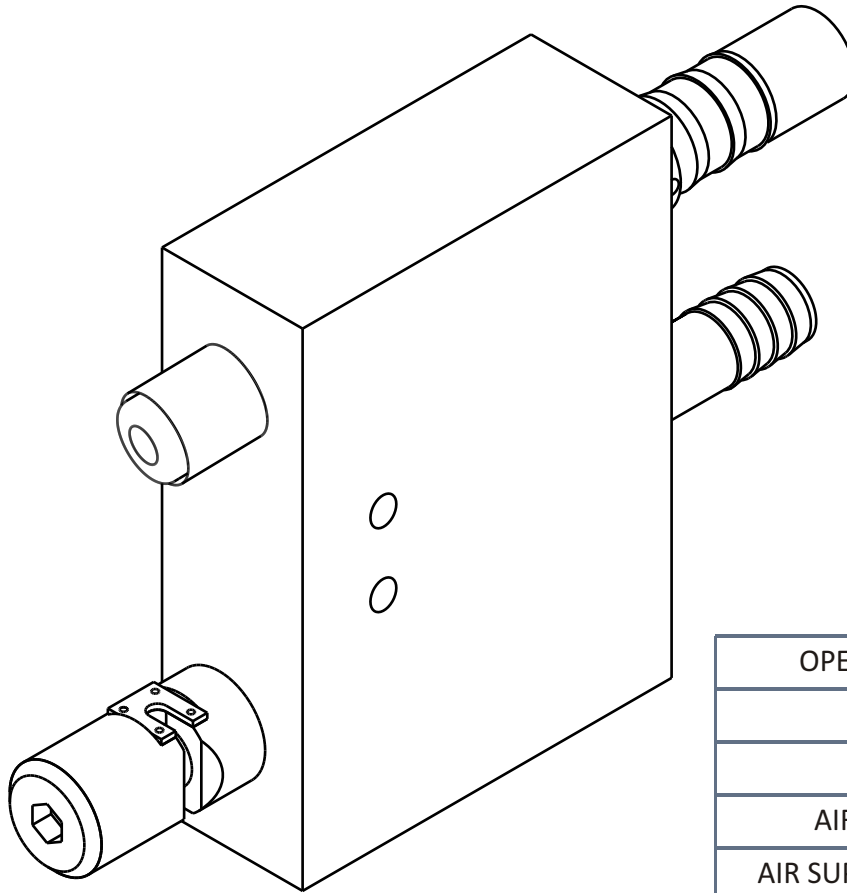

A140CC28 R(L)

SPECIFICATIONS

OPERATING PRESSURE :	4-9 BAR (kg/cm ²)
YARN SPEED :	upto 8000 mtr/min
TOTAL YARN SIZE :	35000 (dtex)
AIR SUPPLY- CUTTER :	6 mm OD PIPE
AIR SUPPLY CONNECTION :	20 mm OD PIPE
AIR EXHAUST CONNECTION :	30 mm ID HOSE
AIR CONSUMPTION :	38X(BAR+1) m ³ /hr
OVERALL DIMENSION :	263X40X120 mm
WEIGHT :	2.20 kg

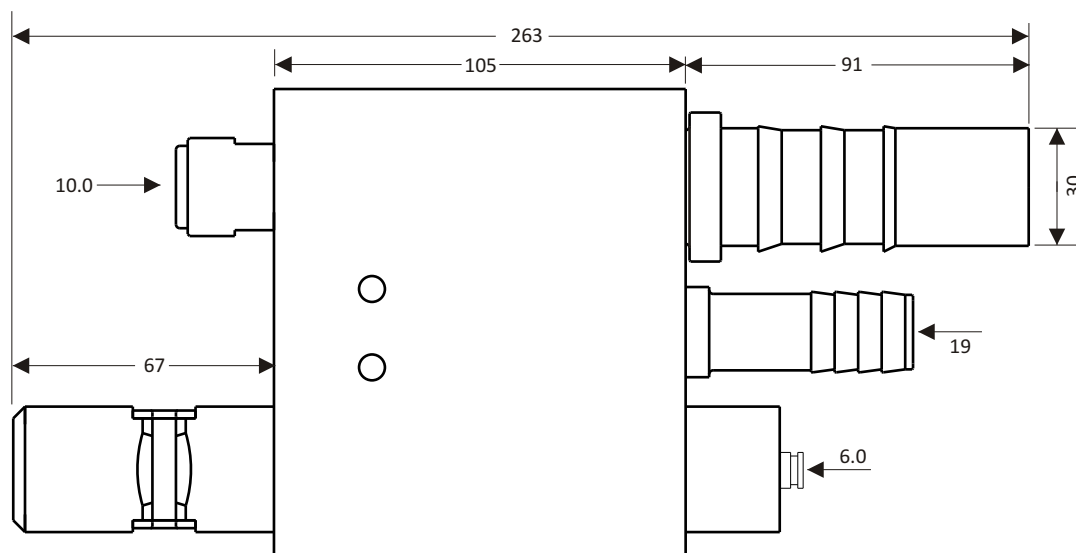

Other modifications on request

REPLACEMENT FOR : LufanStat-Cut LC10-I100