

# Yarn Gathering + Cutting + Suction Unit

# PAWAN CAXB

Automatic unit under duct for gathering 4/8/12 ends+cut&suck actuated by electric sensor or press button. Can replace 4/8 aspirator & cutters. Old design individual aspirator & cutter system can be replaced with less parts & reduced air consumption



TOP VIEW

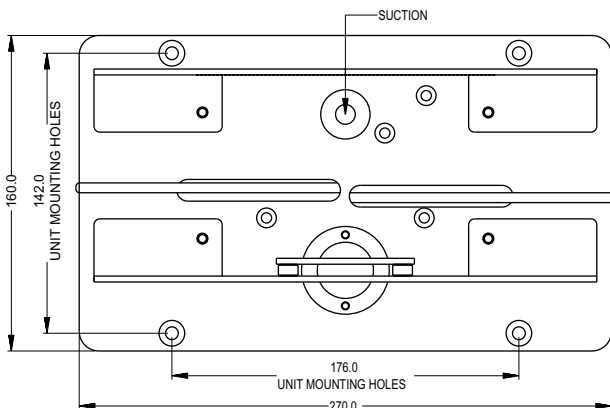
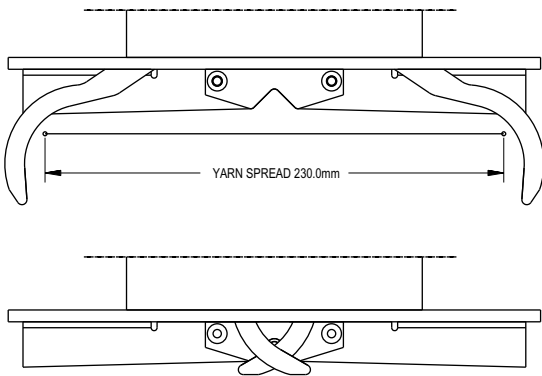

FRONT VIEW

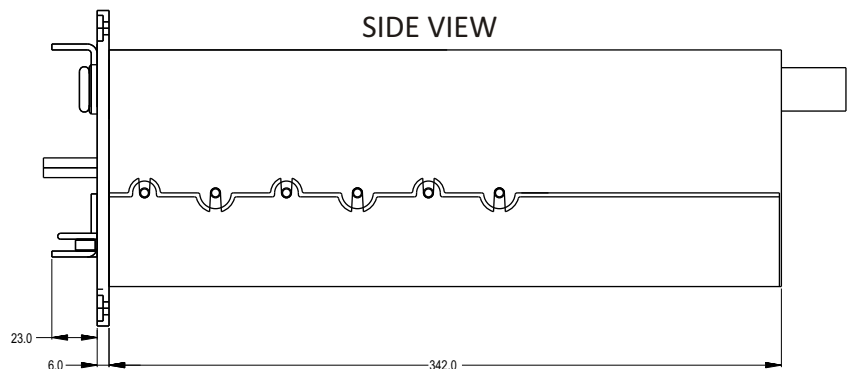

SIDE VIEW

## SPECIFICATIONS

- APPLICATION : SPINNING PLANTS
- OPERATING PRESSURE FOR OPERATION : 4-6 BAR (kg/cm<sup>2</sup>)
- OPERATING PRESSURE FOR ASPIRATOR : 4-8 BAR (kg/cm<sup>2</sup>)
- ELECTRIC SUPPLY FOR SOLENOID : 24 V DC
- AIR SUPPLY ASPIRATOR : 12 mm OD PIPE
- AIR EXHAUST CONNECTION : 22 mm ID Hose
- AIR CONSUMPTION : 12.5(BAR+1) m<sup>3</sup>/hr
- OVERALL DIMENSION : 410X270X130 mm

Other modifications on request

REPLACEMENT FOR BARMAG